



Assembly Instructions



ITEM NO. D1719-50S
 CORI ROUND DINING TABLE
 CORI DINING CHAIR (SET INCLUDES 4 CHAIRS)

Thank you for purchasing this quality product. Be sure to check all packing materials carefully for small parts, which may have come loose inside the carton during shipment. Identify and count all items and compare with the PARTS LIST and/or HARDWARE LIST shown below.



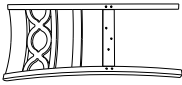
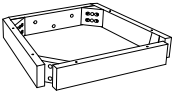
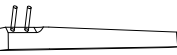

Caution: Please read the instructions thoroughly before assembly.

1. We recommend that you assemble this product with the assistance of another person; this will make the assembly easier, and will help eliminate damage to the product or injury to persons during assembly.
2. Please do not over tighten screws or bolts until the assembly is completed.
3. Please put all parts on a non-abrasive floor before assembly, and follow the assembly steps to assemble your newly purchased product correctly and efficiently.

PARTS LIST

| NO. | COMPONENT | SKETCH | QTY. |
|-----|--------------|---|-------|
| A | CHAIR BACK |  | 4 PCS |
| B | SEAT FRAME |  | 4 PCS |
| C | FRONT LEG |  | 8 PCS |
| D | CUSHION SEAT |  | 4 PCS |

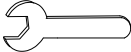
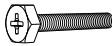
HARDWARE LIST

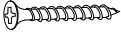
| NO. | COMPONENT | SKETCH | QTY. |
|-----|------------------------------|---|--------|
| 1 | FLAT WASHER 5/16" DIA. |  | 44 PCS |
| 2 | SPRING WASHER 5/16" DIA. |  | 44 PCS |
| 3 | NUT 5/16" DIA. |  | 16 PCS |
| 4 | ALLEN WRENCH 5/16" DIA. |  | 1 PC |
| 5 | SHORT BOLT 1/4" x 1 3/4" |  | 12 PCS |
| 6 | LONG BOLT 1/4" x 3" |  | 16 PCS |
| 7 | WOOD SCREW 5/32" x 1 1/2" |  | 24 PCS |

Assembly Instructions

ITEM NO. D1719-50S

CORI ROUND DINING TABLE

CORI DINING CHAIR (SET INCLUDES 4 CHAIRS)

To assemble the chairs, please follow the following steps and repeat for each chair:

STEP 1

Lay the chair back on soft clean surface and install the seat frame.

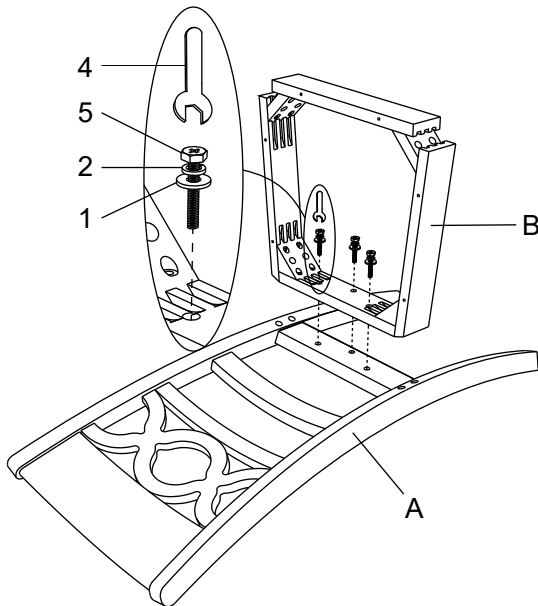

STEP 2

Insert long bolts to secure the seat frame.

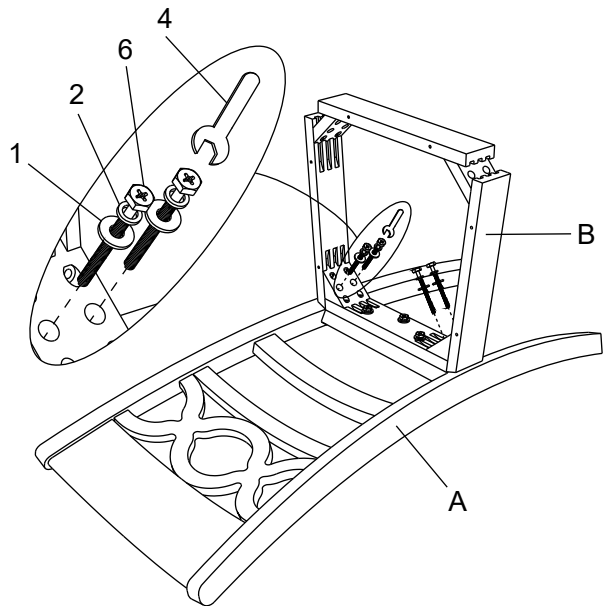

STEP 3

Install the chair front legs once the seat frame is secured.

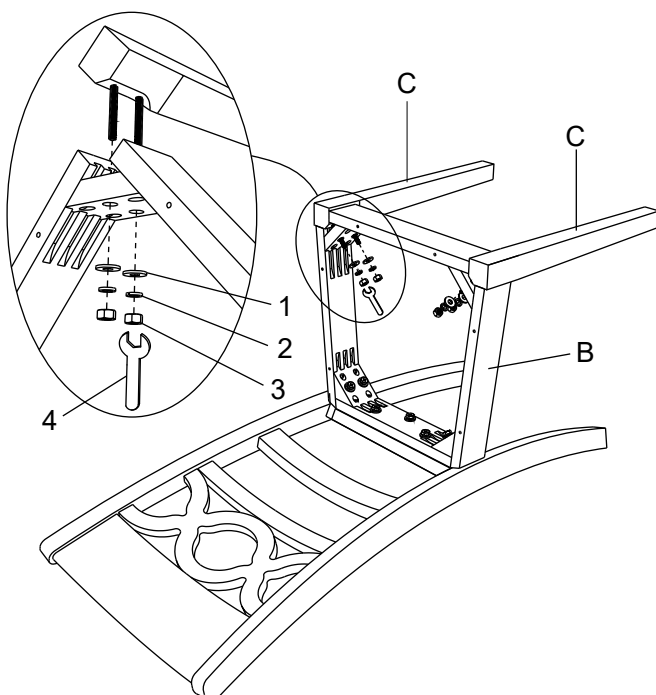

STEP 4

Place the assembled seat frame on the cushion seat and attach with wood screws.

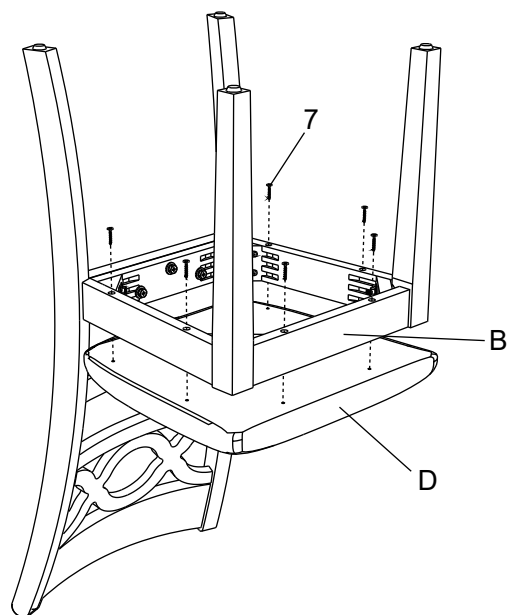



Assembly Instructions

ITEM NO. D1719-50S



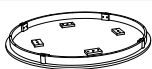
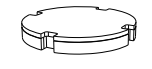

CORI ROUND DINING TABLE

CORI DINING CHAIR (SET INCLUDES 4 CHAIRS)

PARTS LIST

| NO. | COMPONENT | SKETCH | QTY. |
|-----|--------------|---|-------|
| A | TABLE TOP |  | 1 PC |
| B | MIDDLE SHELF |  | 1 PC |
| C | TABLE LEG |  | 4 PCS |

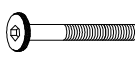
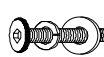
HARDWARE LIST

| NO. | COMPONENT | SKETCH | QTY. |
|-----|-----------------------------|---|-------|
| 1 | SPRING WASHER 5/16" DIA. |  | 4 PCS |
| 2 | FLAT WASHER 5/16" DIA. |  | 4 PCS |
| 3 | LONG BOLT 5/16" x 2 1/2" |  | 4 PCS |
| 4 | SHORT BOLT 1/4" x 1" |  | 8 PCS |
| 5 | ALLEN KEY 1/4" DIA. |  | 1 PC |

To assemble the table, please follow the following steps but do not tighten all bolts:

STEP 1: Install 3 of the table legs first.

STEP 2: Install the middle shelf.

STEP 3: Install the last table leg.

STEP 4: Turn the table to the upright position carefully and make sure the table is level, then tighten all bolts.

