

MODEL : B1334-110/120/330 EASTERN KING BED

(B1334-110)
BOX OF HEADBOARD

NO	ITEM	QTY
A	Headboard	1
B	Headboard Leg (L&R)	2

(B1334-120)
BOX OF FOOTBOARD

NO	ITEM	QTY
C	Footboard	1
D	Slat	4
E	Slat support	8

(B1334-330)
BOX OF SIDE RAIL

NO	ITEM	QTY
F	Side Rail	2

(B1334-110)
HARDWARE LIST

NO	ITEM	QTY
1	JCBC BOLT M6 x 40MM	4 PCS
2	JCBC BOLT M6 x 80MM	2 PCS
3	SPRING WASHER 1/4" RBW	4 PCS
4	FLAT WASHER 1/4" ID x 19mmOD BLK	4 PCS
5	WOOD DOWEL 10mmx30mm	2 PCS
6	ALLEN KEY M4 x 110MM	1 PCS

(B1334-120)
HARDWARE LIST

NO	ITEM	QTY
7	CSK SCREW M4 x 32MM RBW	8 PCS

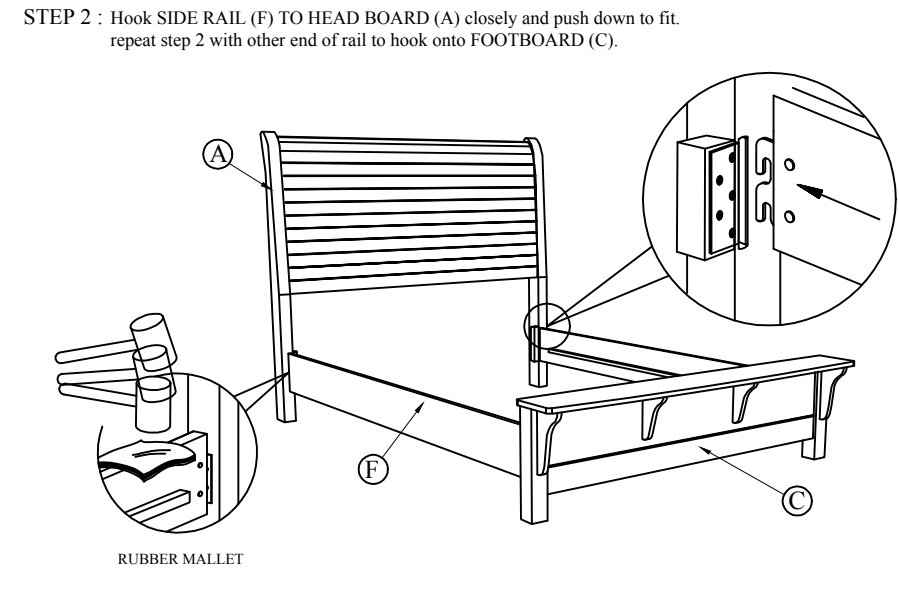
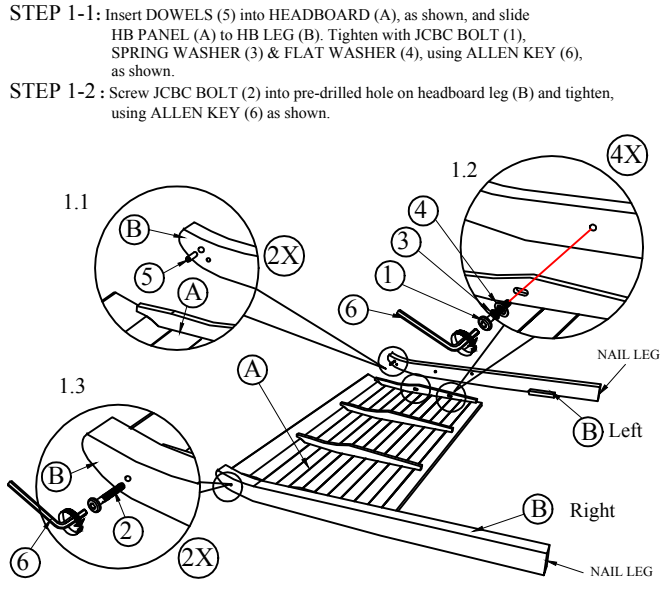

STEP 3: Fix the Bed Slats Support (E) to Bed Slats (D) as Shown and fix the Bed Slats to Side Rail (F) by using Flat Head Chipboard Screw (7). Loosen or Tighten the Adjuster as necessary to level the bed. Bed assembly should be done in final location to ensure stability.

